

STEP #1
COVER REMOVAL

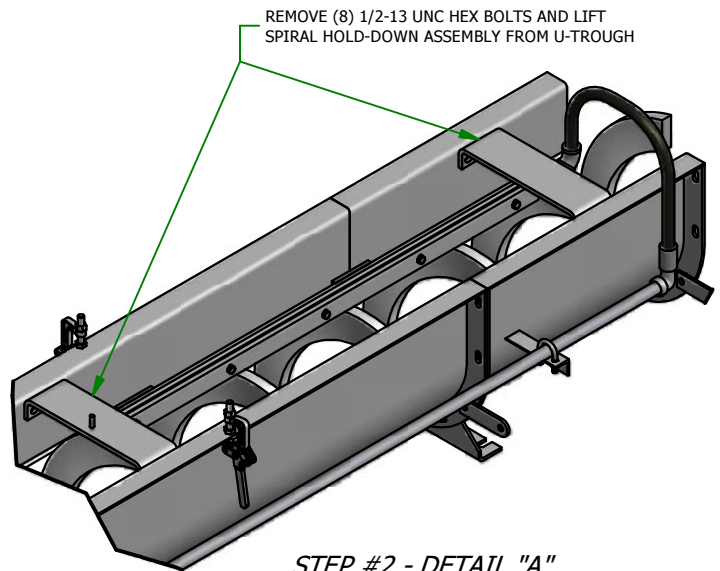

STEP #2 - DETAIL "A"
HOLD-DOWN REMOVAL

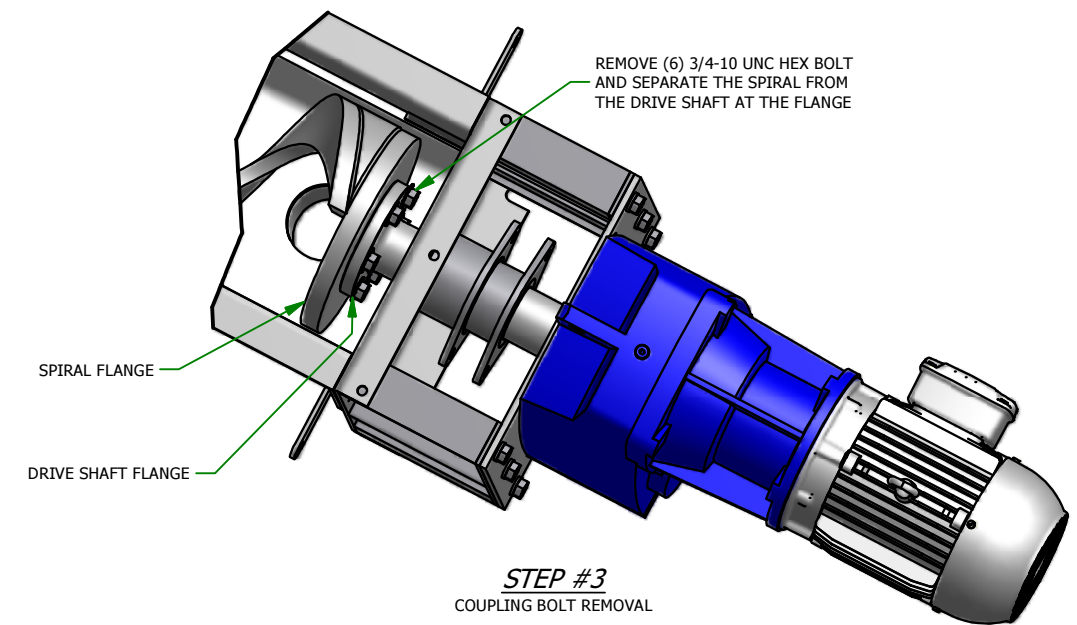

STEP #3
COUPLING BOLT REMOVAL

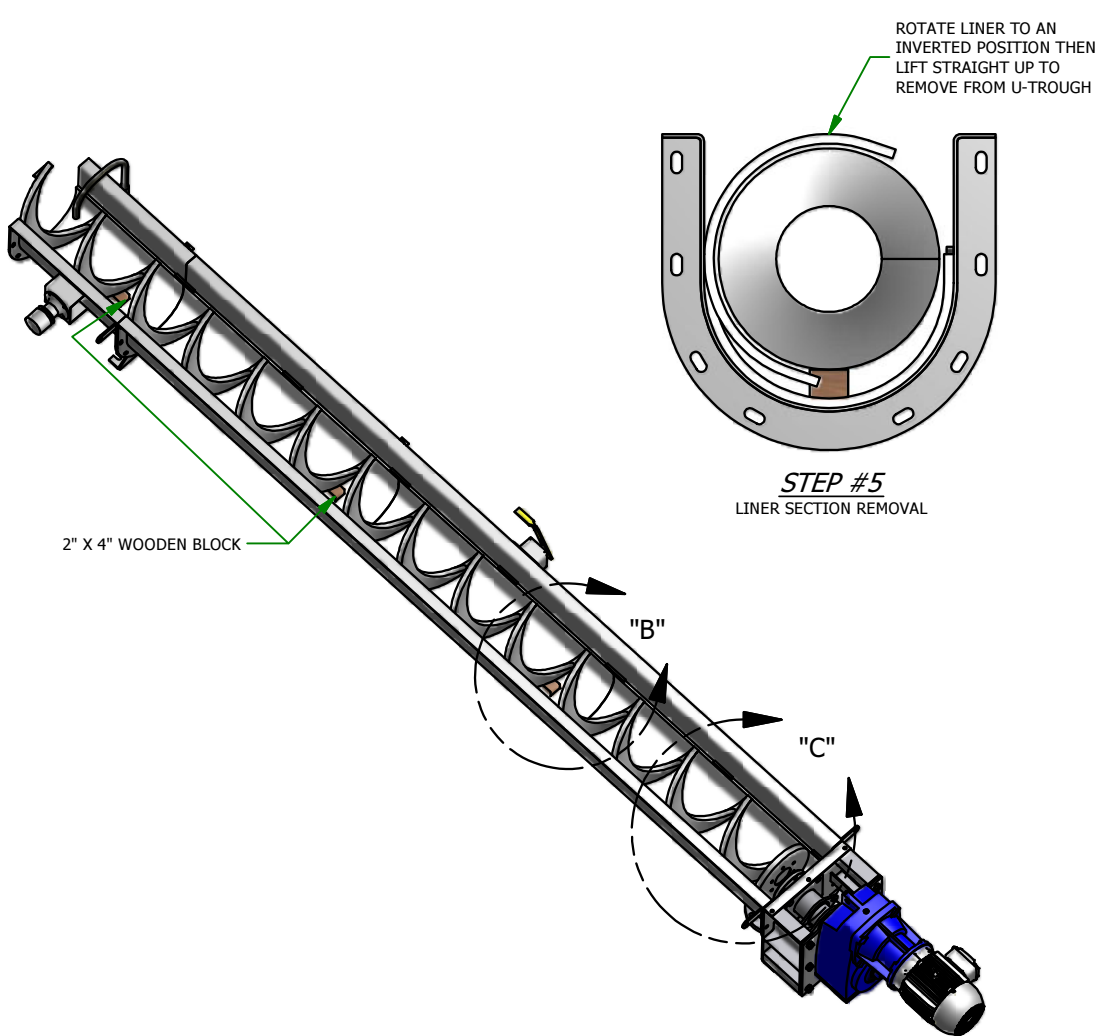

STEP #4
LIFT AND SUPPORT SPIRAL

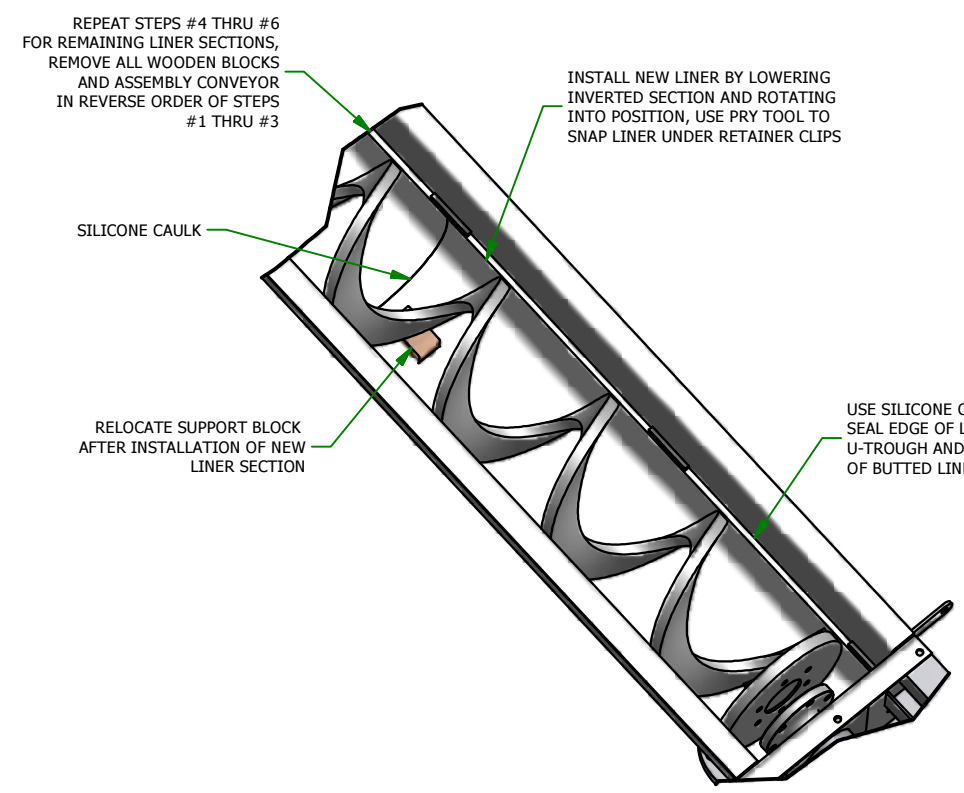

STEP #5
LINER SECTION REMOVAL

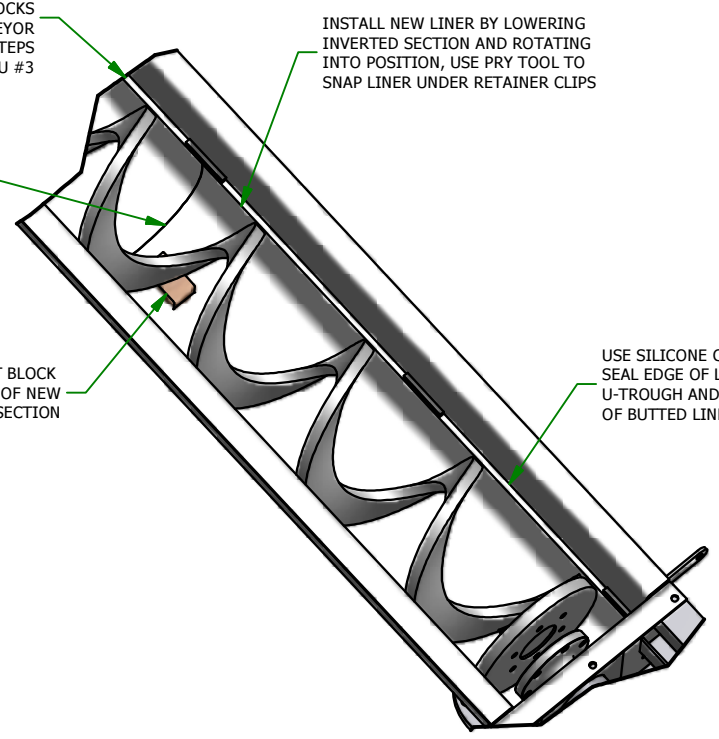

STEP #6
NEW LINER INSTALLATION

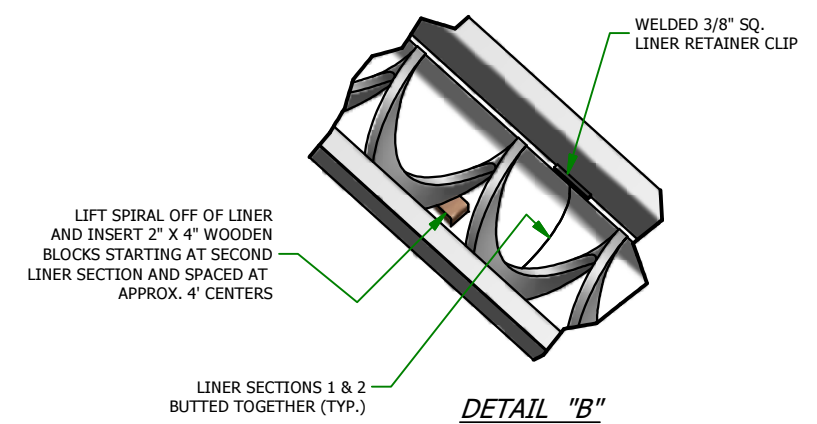

DETAIL "B"

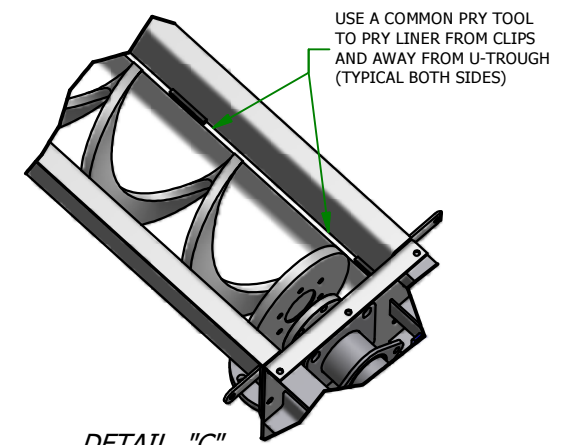

DETAIL "C"
LINER REMOVAL

REVISIONS			
NO.	DATE	BY	DESCRIPTION
1			

SECTION No.
PAGE No.
SHAFTLESS SCREW
CONVEYOR
LINER REPLACEMENT
TYPICAL FOR CONVEYORS

KWS Design Engineering Manufacturing

KWS MANUFACTURING CO., LTD.
3041 CONVEYOR DRIVE
BURLESON, TX 76028
Phone: (817) 295-2247
Fax: (817) 447-8528
Website: www.kwsmfg.com
Email: sales@kwsmfg.com

ENGINEERING STANDARD

DRAWING BY: NJR CHECKED BY: DATE: 10/28/2011 SCALE: N/A DRAWING NO.: REV.: