

# FIXED LADDERS



## Fixed Steel Ladders

# SERIES "F" & SERIES "M"

**COTTERMAN® FIXED STEEL LADDERS** are designed for use where safe, solid vertical climbing access is required. Series F and Series M modular fixed steel ladders are available with and without walk-thru handrails at the top landing surface. Standard fixed and walk-thru models can be used up to 24' without safety cages. OSHA requires safety cages on ladder heights exceeding 24'. Separate cages are offered for updating older ladders to current safety standards. All Cotterman® fixed ladders meet applicable OSHA and ANSI standards.

**SERIES F FIXED LADDERS:** Ladders are heavy duty welded assemblies

**SERIES M MODULAR FIXED LADDERS:** Ladders are heavy duty sub-assemblies, no section is greater than 7' in length.

### CONSTRUCTION FEATURES:

- Side members are 1/4"x2"x2" steel angle. Climbing rungs are 3/4" corrugated steel round rungs space on 12" centers. Stand-off brackets are 7".

**FIXED LADDER WITH WALK-THRU HANDRAILS:** Ladders are designed for applications where safe landing access is required. They are one-piece welded assemblies for use in applications less than 20' in vertical height.

### CONSTRUCTION FEATURES:

- Side members are 1/4"x2"x2" steel angle. 3/4" corrugated steel round climbing rungs on 12" centers. Stand-off mounting brackets are 7".
- Walk-thru handrails extend 42" above landing surface. Mounting brackets included.
- Welded one-piece.

**FIXED LADDERS WITH SAFETY CAGES:** Standard fixed steel ladders are combined with safety cage protection. Available in 10' through 29' sizes and ideal for hatch-way or side-step landing access.

### CAGE FEATURES:

- Cages have flared bottom opening for easy entry.
- Left or right side step access cage designs are available at no charge.
- Cage begins 7' from bottom of ladder.

**FIXED LADDER WITH WALK-THRU HANDRAILS AND SAFETY CAGES:** Designed for safe landing access and available from 10' to 29'. Cages and walk-thru handrails extend 42" above landing surface.

### CAGE FEATURES:

- Cages have flared bottom opening for easy entry.
- Cage begins 7' from bottom of ladder.

**All: gray powder coat finish, yellow also available.**



14 Rung  
Standard  
**F14S**

14 Rung  
with Cage  
**F14SC**



11 Rung  
with Walk-Thru  
**F11W**

11 Rung  
with Walk-Thru  
& Cage: **F11WC**

## Series "M" modular fixed ladder construction

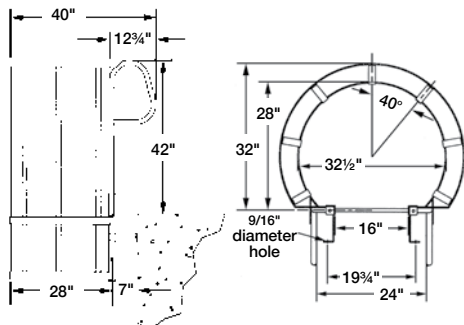

## Series "F" construction features

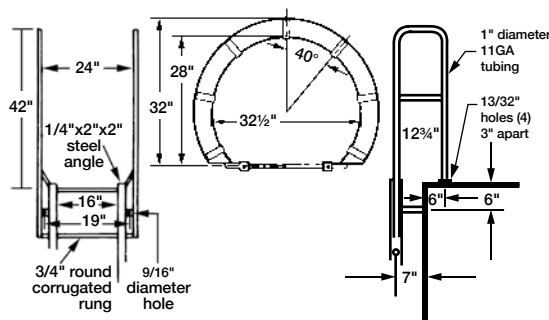

# FIXED LADDERS

## Fixed Ladders - SERIES F & SERIES M MODEL NUMBERS & MEASUREMENTS



LENGTH-TOP TO BOTTOM RUNG	NO. RUNGS	STANDARD		WITH CAGE			OVERALL LENGTH	WALK THRU-RAIL			WITH WALK THRU & CAGE			OVERALL LENGTH
		SERIES "F" MODEL NUMBER	SHIPPING WEIGHT LBS.	SERIES "F" MODEL NUMBER	SERIES "M" MODEL NUMBER	SHIPPING WEIGHT LBS.		SERIES "F" MODEL NUMBER	SERIES "M" MODEL NUMBER	SHIPPING WEIGHT LBS.	SERIES "F" MODEL NUMBER	SERIES "M" MODEL NUMBER	SHIPPING WEIGHT LBS.	
3'	4	F4S	35				3'3"	F4W	M4W	61				6'8"
4'	5	F5S	43				4'3"	F5W	M5W	70				7'8"
5'	6	F6S	52				5'3"	F6W	M6W	78				8'8"
6'	7	F7S	60				6'3"	F7W	M7W	87				9'8"
7'	8	F8S	66				7'3"	F8W	M8W	95	F8WC	-	167	10'8"
8'	9	F9S	77				8'3"	F9W	M9W	104	F9WC	-	194	11'8"
9'	10	F10S	88				9'3"	F10W	M10W	115	F10WC	-	211	12'8"
10'	11	F11S	96	F11SC	M11SC	156	10'3"	F11W	M11W	123	F11WC	M11WC	226	13'8"
11'	12	F12S	105	F12SC	M12SC	182	11'3"	F12W	M12W	132	F12WC	M12WC	242	14'8"
12'	13	F13S	113	F13SC	M13SC	197	12'3"	F13W	M13W	140	F13WC	M13WC	268	15'8"
13'	14	F14S	122	F14SC	M14SC	213	13'3"	F14W	M14W	148	F14WC	M14WC	284	16'8"
14'	15	F15S	130	F15SC	M15SC	268	14'3"	F15W	M15W	157	F15WC	M15WC	327	17'8"
15'	16	F16S	139	F16SC	M16SC	282	15'3"	F16W	M16W	165	F16WC	M16WC	353	18'8"
16'	17	F17S	150	F17SC	M17SC	298	16'3"	F17W	M17W	176	F17WC	M17WC	369	19'8"
17'	18	F18S	158	F18SC	M18SC	316	17'3"	F18W	M18W	185	F18WC	M18WC	384	20'8"
18'	19	F19S	167	F19SC	M19SC	342	18'3"	F19W	M19W	193	F19WC	M19WC	401	21'8"
19'	20	F20S	175	F20SC	M20SC	357	19'3"	F20W	M20W	202	F20WC	M20WC	428	22'8"
20'	21			F21SC	M21SC	373	20'3"			-	F21WC	M21WC	443	23'8"
21'	22			F22SC	M22SC	388	21'3"			-	F22WC	M22WC	458	24'8"
22'	23			F23SC	M23SC	414	22'3"			-	F23WC	M23WC	485	25'8"
23'	24			F24SC	M24SC	429	23'3"			-	F24WC	M24WC	500	26'8"
24'	25			F25SC	M25SC	444	24'3"			-	F25WC	M25WC	515	27'8"
25'	26			F26SC	M26SC	471	25'3"			-	F26WC	M26WC	571	28'8"
26'	27			F27SC	M27SC	486	26'3"			-	F27WC	M27WC	586	29'8"
27'	28			F28SC	M28SC	501	27'3"			-	F28WC	M28WC	601	30'8"
28'	29			F29SC	M29SC	559	28'3"			-	F29WC	M29WC	619	31'8"
29'	30			F30SC	M30SC	575	29'3"			-	F30WC	M30WC	634	32'8"

SHIPPING NOTE: All 15 thru 28 rung Series "F" models with cages ship in 2 sections. All 29 and 30 rung models ship in 3 sections.

Hot Dip Galvanized finish or Stainless Steel construction can be quoted.

SHIPPING NOTE: All 15 thru 25 rung Series "F" models with cages and walk thru handrails ship in 2 sections. All 26 and 30 rung models ship in 3 sections.

## ACCESSORIES

Cotterman® fixed steel ladder accessories are designed to provide an additional measure of safety or security for any fixed steel ladder.

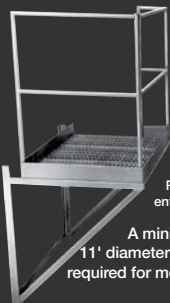

### SP Standoff Landing Platform

Standoff landing platforms used with offset caged ladders. These rugged, pre-engineered platforms are constructed with left or right entries as required.

Right Side entry shown

A minimum of 11" diameter surface required for mounting.

OPTION SP shipping weight 153 lbs.

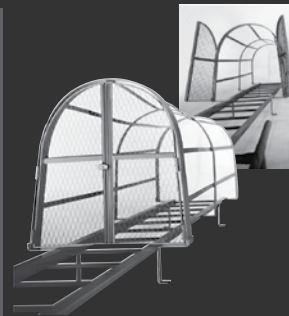

### CG Security Cage Entry Gate

The cage security gate is designed to prevent unauthorized entry into the bottom of the ladder cage. Doors have lockable hasp.

OPTION CG shipping weight 31 lbs.



### LG Security Ladder Guard

The ladder guard is mounted directly over the ladder climbing rungs to prevent unauthorized use. It is available in either 6' or 8' lengths. The guard has a one-piece piano hinge, and is furnished with lock-open and lock-closed hasps.

OPTION LG-6 shipping weight 130 lbs.

OPTION LG-8 shipping weight 148 lbs.

# SERIES "C"

## Welded Steel Cages

**COTTERMAN® SERIES "C"** welded steel cages are one-piece welded assemblies designed for attachment to existing fixed ladders up to 20" wide. A wide range of standard lengths is offered with custom sizes available. To determine the proper length, the cage should begin 7' to 8' from the floor and extend 42" above the landing surface (except for roof hatches).

- Series "C" cages meet applicable OSHA and ANSI standards.
- Standard cage lengths are available from 7'6" to 27'6".
- Cages are crated for shipping protection.
- Wider bottom flare openings are provided for easy entry.
- One-piece all welded steel with gray powder coat finish.
- Hot dip galvanized finish or stainless steel construction can be quoted.



## SERIES "C"

### MODEL NUMBERS & MEASUREMENTS

LENGTH	MODEL NUMBER	SHIPPING WEIGHT LBS.
7'6"	<b>C075</b>	229
8'6"	<b>C085</b>	255
9'6"	<b>C095</b>	291
10'6"	<b>C105</b>	316
11'6"	<b>C115</b>	340
12'6"	<b>C125</b>	365
13'6"	<b>C135</b>	401
14'6"	<b>C145</b>	426
15'6"	<b>C155</b>	451
16'6"	<b>C165</b>	476
17'6"	<b>C175</b>	512
18'6"	<b>C185</b>	536
19'6"	<b>C195</b>	561
20'6"	<b>C205</b>	586
21'6"	<b>C215</b>	622
22'6"	<b>C225</b>	646
23'6"	<b>C235</b>	671
24'6"	<b>C245</b>	696
25'6"	<b>C255</b>	732
26'6"	<b>C265</b>	756
27'6"	<b>C275</b>	781

## Welded Steel BOLT-ON MODULAR SAFETY CAGES

Gray powder-coated paint finish Modular cages help make existing fixed ladder OSHA compliant. Cages mount to the side rails of fixed ladders up to 20" wide. Top and middle sections have a 29" inside diameter; bottom section flares to a 34" inside diameter for easy entry. Include mounting hardware for flat or angle side rails.

To determine proper length, the cage should begin 7 ft. to 8 ft. from the floor and extend 42" above the landing surface (except for roof hatches). 1 top or middle section and 1 bottom section is required for a complete assembly. Meet applicable OSHA and ANSI standards.



MODEL NUMBER	DESCRIPTION
<b>2MS</b>	2' mid section, bolt on
<b>2BC</b>	2' bottom section, bolt on
<b>3MS</b>	3' mid section, bolt on
<b>3BC</b>	3' bottom section, bolt on
<b>4MC</b>	4' mid section, bolt on
<b>4BC</b>	4' bottom section, bolt on
<b>5WC</b>	5' top section walk-thru, bolt on
<b>7MC</b>	7' mid section, bolt on



- Pickled & Oiled structural steel, for improved finish.
- Bolt-together design allows for easy field assembly.

flexible, versatile and easy-to-assemble design  
with a superior corrosion-resistant finish

**COMING SOON!**

**NEW FULLY MODULAR  
FIXED LADDER  
SYSTEM**